





## Dear Customer

This Getting Started contains information about the daily use of your Bang & Olufsen product and connected equipment. We expect your retailer to deliver, install and set up your product.

Your television offers more features and functions than described in this Getting Started. Among other things; Timer functions and auto standby. These and other features are described in more detail in the product's Guide.

The Guides are found on [www.bang-olufsen.com/guides](http://www.bang-olufsen.com/guides).

The Guides are also kept up to date if new software introduces new or modified features and functions in your television.

On [www.bang-olufsen.com](http://www.bang-olufsen.com) you can also find further information and relevant FAQs about your product.

Your Bang & Olufsen retailer is your first stop for all your service queries.

*To find your nearest retailer, visit our website ...*

[www.bang-olufsen.com](http://www.bang-olufsen.com)

**WARNING:** To reduce the risk of fire or electric shock, do not expose this appliance to rain or moisture.

The product can only be switched off completely by disconnecting it from the mains socket. The mains socket must always be accessible.



The lightning flash with arrowhead symbol within an equilateral triangle, is intended to alert the user to the presence of uninsulated "dangerous voltage" within the product's enclosure that may be of sufficient magnitude to constitute a risk of electric shock to persons.



The exclamation point within an equilateral triangle is intended to alert the user to the presence of important operating and maintenance (servicing) instructions in the literature accompanying the product.

Read these instructions.

Keep these instructions.

Heed all warnings.

Follow all instructions.

Do not use this apparatus near water.

Clean only with dry cloth.

Do not block any ventilation openings. Install in accordance with the manufacturer's instructions.

Do not install near any heat sources such as radiators, heat registers, stoves, or other apparatus (including amplifiers) that produce heat.

Do not defeat the safety purpose of the polarized or grounding-type plug. A polarized plug has two blades with one wider than the other. A grounding type plug has two blades and a third grounding prong. The wide blade or the third prong are provided for your safety. If the provided plug does not fit into your outlet, consult an electrician for replacement of the obsolete outlet.

Protect the power cord from being walked on or pinched particularly at plugs, convenience receptacles, and the point where they exit from the apparatus.

Only use attachments/accessories specified by the manufacturer.



Use only with the cart, stand, tripod, bracket, or table specified by the manufacturer, or sold with the apparatus. When a cart is used, use caution when moving the cart/apparatus combination to avoid injury from tip-over.

Unplug this apparatus during lightning storms or when unused for long periods of time.

Refer all servicing to qualified service personnel. Servicing is required when the apparatus has been damaged in any way, such as power-supply cord or plug is damaged, liquid has been spilled or objects have fallen into the apparatus, the apparatus has been exposed to rain or moisture, does not operate normally, or has been dropped.

The mains plug of the power supply cord shall remain readily operable.

Do not expose batteries or battery packs to excessive heat such as sunshine, fire or the like.

Follow instructions to ensure correct and safe installation and interconnection of equipment in multimedia systems.

# Contents

## Daily use

- 6 How to use your remote control
- 8 Introduction
- 10 Watch television
- 12 Watch 3D television
- 14 Change sound type and picture format
- 15 Use the Adaptive Sound Technology

## Installation and setting up

- 18 Set up your television
- 19 Cleaning
- 20 Connection panels
- 22 First-time setup of your television

## Cautions

- Ensure that the television is positioned, set up and connected in accordance with the instructions in this Getting Started. To prevent injury, use Bang & Olufsen approved stands and wall brackets only!
- Place your television on a firm, stable surface.
- Do not place any items on top of your television.
- Do not subject the television to rain, high humidity or sources of heat.
- The television is intended for indoor use in dry, domestic environments only. Use within a temperature range of 50–95°F (10–35°C), and at an altitude of no more than 5,000 ft (1,500 m).
- Do not place the television in direct sunlight or direct artificial light, such as a spotlight, as this may reduce the sensitivity of the remote control receiver. Also if the screen is overheated, black spots may appear in the picture. These spots disappear again, once the television cools down to normal temperature.
- Leave enough space around the television for adequate ventilation.
- Connect all cables before connecting or reconnecting any of the products in your system to the mains.
- No naked flame sources, such as lighted candles should be placed on the apparatus.
- To prevent the spread of fire, keep candles or other open flames away from this product at all times.
- Do not attempt to open the television. Leave such operations to qualified service personnel.
- Do not strike the glass with hard or pointed items.
- The television can only be switched off completely by disconnecting it from the wall socket.
- The disconnect device shall remain readily operable.
- The supplied plug and mains cord are specially designed for the product. Do not change the plug and if the mains cord is damaged, you must buy a new one from your Bang & Olufsen retailer.









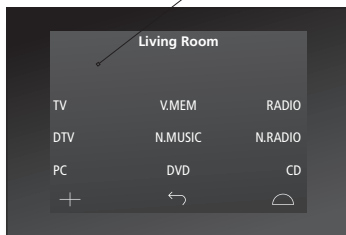





# How to use your remote control

## Beo6 operation



Your television can be operated with the Beo6 remote control as described in this Getting Started and the Guide, but you can also operate your television with Beo5 which is operated similarly to Beo6.



-  **TV** Soft button, touch screen to select\*<sup>1</sup>  
Switch on a source or select a function
-  **Back up through Beo6 displays**
-  **Bring up Scene buttons, such as Zones or Speaker**  
Press again to return
-  **Bring up digits to select channel**  
Press again to return
-  **STOP** Pause and stop playback or recording
-  **PLAY** Start playback of a disc or recording
-  **BACK** Move backwards through menus. Long press to exit menus completely
-  **Select colour specific functions\*<sup>2</sup>**  
Press volume wheel next to the colour
-  **Turn to adjust volume**  
To mute, turn quickly counter-clockwise
-  **Centre button is used for selecting and accepting**
-  **Navigation button left, right, up and down – move in menus by pressing the button in the direction you need**
-  **Rewind or wind, search backwards or forwards**
-  **Step through channels or recordings**  
Hold for continuous step
-  **Standby**

**Important** – for more information: [www.bang-olufsen.com](http://www.bang-olufsen.com)

<sup>1</sup>**About buttons** Light grey buttons indicate that you have to press a text in the display. Dark grey buttons indicate that you have to press a hard button.

<sup>2</sup>**Coloured buttons** Press the wheel next to the colour to activate a coloured button.

**Actual zone** Indicates the actual zone on Beo6 as it was named during the setup process.

**Soft buttons on Beo6** Depending on the activated source, different soft buttons appear on the screen. Touch the screen to activate the function.

## Beo4 operation

You can also operate your television with a Beo4. When Beo4 operation is different from Beo6 operation, it is described separately.

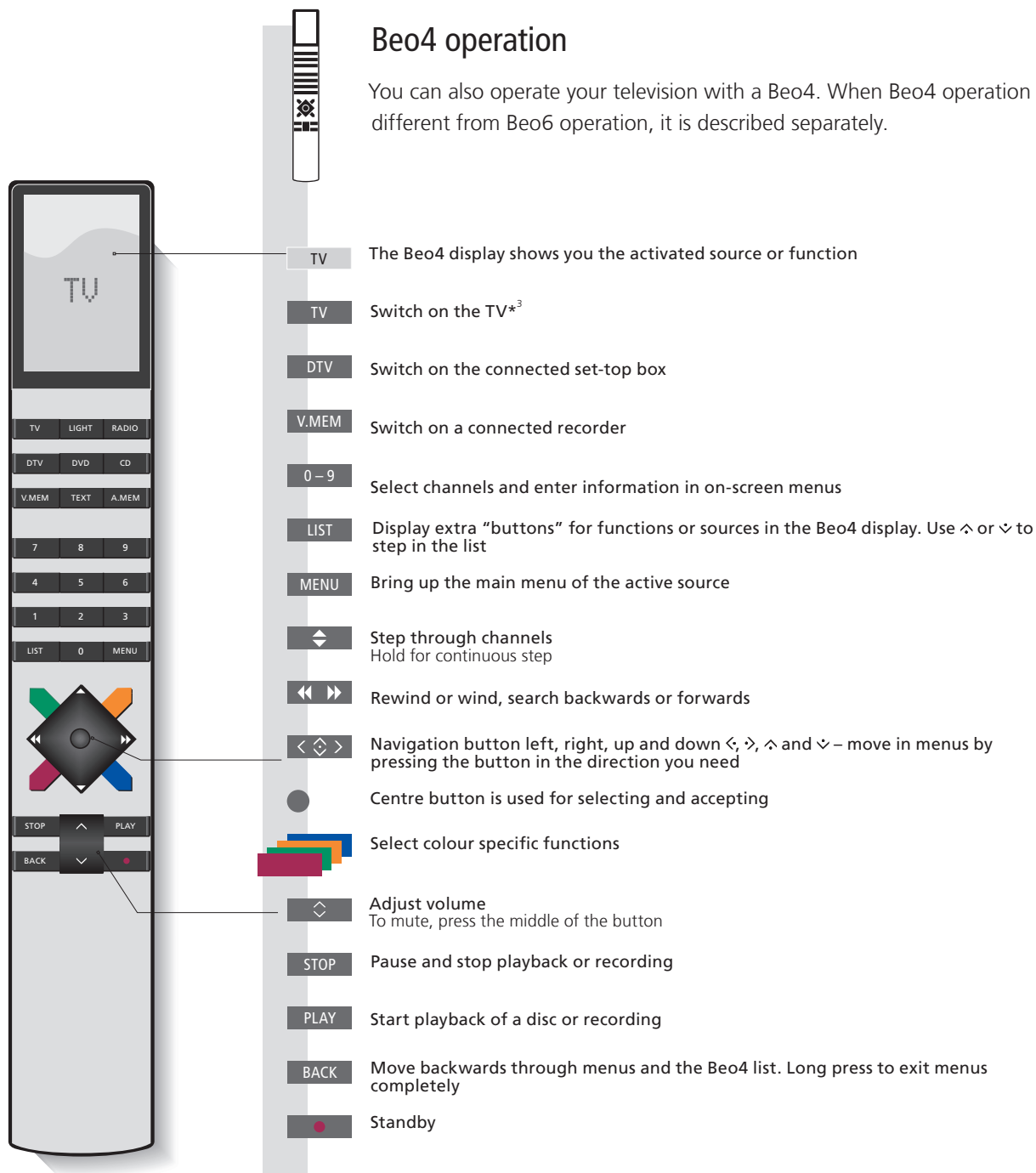

- TV** The Beo4 display shows you the activated source or function
- TV** Switch on the TV\*<sup>3</sup>
- DTV** Switch on the connected set-top box
- V.MEM** Switch on a connected recorder
- 0 – 9** Select channels and enter information in on-screen menus
- LIST** Display extra “buttons” for functions or sources in the Beo4 display. Use  $\wedge$  or  $\vee$  to step in the list
- MENU** Bring up the main menu of the active source
- $\blacktriangle$   $\blacktriangledown$  Step through channels  
Hold for continuous step
- $\blacktriangleleft$   $\blacktriangleright$  Rewind or wind, search backwards or forwards
- $\blacktriangleleft$   $\blacktriangleright$   $\blacktriangle$   $\blacktriangledown$  Navigation button left, right, up and down  $\blacktriangleleft$ ,  $\blacktriangleright$ ,  $\blacktriangle$  and  $\blacktriangledown$  – move in menus by pressing the button in the direction you need
- $\bullet$  Centre button is used for selecting and accepting
-  Select colour specific functions
- $\blacklozenge$  Adjust volume  
To mute, press the middle of the button
- STOP** Pause and stop playback or recording
- PLAY** Start playback of a disc or recording
- BACK** Move backwards through menus and the Beo4 list. Long press to exit menus completely
- $\bullet$  Standby

<sup>3</sup>**Beo4 buttons** Some buttons can be reconfigured during the setup process. See the Guide for further information. NOTE! For general information about remote control operation, see the guide enclosed with your remote control.

# Introduction

Navigate in menus and select settings using your remote control. Pressing **Menu** brings up the menu for the selected source.

## Display and menus

Information about the selected source is shown in the display on the remote control. On-screen menus allow you to adjust settings.

Tv Area	TV	Menu
Select TV's zone <sup>1</sup>	Switch on TV	Show menu

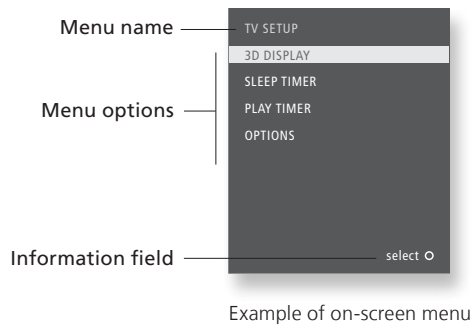

## Important

<sup>1</sup>\***Zone** Zones are named in the Beo6 configuration.



## Navigate in menus

When a menu is on the screen, you can move between menu options, reveal settings or enter data.



Select option/  
setting



Enter data



Bring up  
sub-menu/  
store  
setting



Select option



Move  
backwards  
through menus

or



Press and hold to  
exit menus

### Remote control

This Getting Started and the Guide describe operation with the REMOTE CONTROL menu set to NAVIGATION BUTTON. In the OPTIONS menu, you can bring up the REMOTE CONTROL menu and set up your television to be operated with or without a navigation button. Remember to set your Beo4 remote control to the correct mode. Do not change MODE during first-time setup, as this will interrupt the sequence. See the guide enclosed with your remote control or contact your Bang & Olufsen retailer for further information.

# Watch television

Choose a TV channel by its number, switch to another channel or adjust the sound volume.

Activate the TV source to use these functions

Examples of menu options



## Beo6 operation



**Switch on the TV**

**Select a TV channel**

**Bring up a channel list**

**Adjust the volume**

**Record here and now on a recorder**

While recording on a connected recorder you can also watch another recording, source, or TV channel.

**Switch off the TV**

Automatic colour calibration may start automatically.

## Useful hints

### Automatic Colour Management

If the screen turns black with a grey scale bar and a sensor arm that swings down from the television frame upon pressing the standby button, an automatic colour calibration has started. Automatic Colour Management automatically compensates for colour changes on the screen for every 100 hours of use approximately. Do not switch off the television or disconnect it from the mains during the calibration.

**TV**  
Press

**◀** or **+**      **0-9**      **Previous**  
Select      Activate numbers      Select channel      Select previous channel

**Menu**  
Press      Follow on-screen instructions

**○**      **○**  
Adjust volume. To mute, turn quickly counter-clockwise      Turn either way to bring back the sound

**Record**      **Record**      **STOP**      **STOP**  
Start recording      Stop recording

**●**  
Press



## Beo4 operation

**TV**  
Press

**◀** or **0-9**      **0**  
Select      Select channel      Previous channel

**MENU**  
Press      Follow on-screen instructions

**◇**      **◇**      **◇**  
Adjust volume up or down      Press in the middle to mute sound      Press in the middle to bring sound back

**RECORD**      **STOP**  
Press twice to start      Press twice to stop

**●**  
Press

## Watch 3D television

You can enhance the experience of watching television with 3D technology, for example, when you want to watch movies, sports or nature films, if the television screen or projector supports 3D technology.

### Viewing conditions

Place yourself in front of the screen, a little closer than when you normally watch 2D television, and use the 3D glasses. The recommended distance depends on the size of the screen and the picture resolution. If you move too far to the left or right of the centre of the screen, or if you move too far up or down, the quality of 3D TV decreases. Note that not all screens support 3D technology. Contact your retailer for further information.

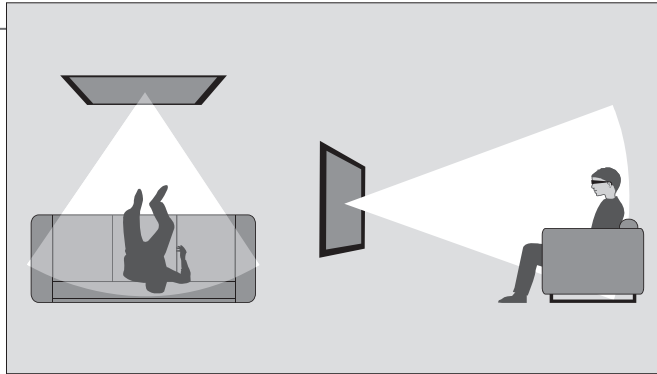

You will get the best 3D experience if you darken the room, for example, switch off the lights and draw the curtains. Especially lights behind and around the screen can cause an irritating effect. We recommend not to watch 3D TV in direct sunlight or bright surroundings.

### Activate 3D or 2D television

To watch films or other programmes suited for 3D, you must activate the 3D function and put on the activated 3D glasses that are available from your retailer. Switch to 2D mode again to watch TV that is not suited for 3D, for example, the news.

Bring up Scene display on Beo6 or TV SETUP menu

Select 3D Display on Beo6 or bring up 3D DISPLAY menu

→ Select 3D or 2D



Accept and watch 3D or 2D respectively, or select mode

3D/2D

If automatic 3D signalling is available, the television automatically switches to 3D when you select 3D and to 2D when you select 2D. If automatic 3D signalling is not available, a menu for 3D or 2D mode selection appears on the screen. See the next page for information about modes.

## Important

### Important health and safety information for 3D pictures

Some viewers may experience discomfort while watching 3D TV such as dizziness, nausea and headaches. If you experience such symptoms, stop watching 3D TV, remove the 3D glasses and rest. Watching 3D TV for an extended period of time may cause eye strain. If you feel eye strain, stop watching 3D TV, remove the 3D glasses and rest. If you use eye glasses or contact lenses, wear the 3D glasses over them. Do not use the 3D glasses for other purposes. Adults should supervise children watching 3D TV and ensure that they do not experience any discomfort as mentioned above. It is recommended that children under 3 years do not watch 3D TV.

### 3D modes

Select the 3D mode that matches the signal sent out by the programme provider.

#### SIDE BY SIDE 3D



Converts side-by-side 3D signal into full screen 3D representation by scaling two pictures horizontally

#### TOP/BOTTOM 3D



Converts top/bottom 3D signal into full screen 3D representation by scaling two pictures vertically

### 2D modes

Select the 2D mode that matches the signal sent out by the programme provider.

#### STANDARD 2D

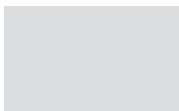

Shows an ordinary 2D TV picture without any conversion.

#### SIDE BY SIDE 2D



Converts side-by-side 3D signal into full screen 2D representation by scaling one picture horizontally

#### TOP/BOTTOM 2D



Converts top/bottom 3D signal into full screen 2D representation by scaling one picture vertically

### Automatic change of mode

If automatic 3D signalling is no longer available, the television automatically switches to the last used mode for the current source. At channel and source change, the television switches to STANDARD 2D.

#### Television screens and projectors

Not all connected television screens and projectors support 3D technology. If a television screen or a projector connected to the system does not support 3D, 3D in the 3D DISPLAY menu is greyed out in TV or CINEMA mode respectively.

#### Dual screen

If two sources are brought up on the screen at the same time, the television will always display a 2D mode.

#### Subtitles

Subtitles may not always be supported.

## Change sound type and picture format

While you watch TV through the television tuner, you can switch between available sound types and adjust the picture format.

### Change sound type or language

Switch between available sound types and languages.

Sound

Bring up sound type\*<sup>1</sup>

Sound

Press repeatedly to switch between available sound types

### Select picture format

The TV automatically adapts the picture to fill out as much of the screen as possible when you select a source, but you can select a format yourself.

Bring up Scene display on Beo6

Select Picture display\*<sup>1</sup>

1-3

Select format\*<sup>2</sup>

Move picture up or down\*<sup>3</sup>

#### FORMAT 1

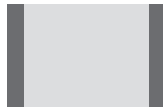

**Standard\*<sup>4</sup>**  
For panoramic view or 4:3

#### FORMAT 2

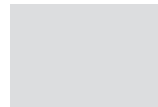

**Zoom**  
The picture is adjusted vertically

#### FORMAT 3

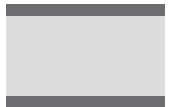

**Wide**  
For a genuine 16:9 widescreen picture

## Useful hints

<sup>1</sup>\***Sound and picture**

<sup>2</sup>\***Optimise**

<sup>3</sup>\***Move picture up or down**

<sup>4</sup>\***Variation**

On Beo4 bring up **SOUND** for sound types and **FORMAT** for picture formats via the **LIST** menu. In order to display **SOUND** and **FORMAT** on Beo4, you must first add it to the Beo4 list of functions. The picture format is optimised, if you press **Optimise** on Beo6. On Beo4, press the **centre** button. The picture can only be moved up or down in **Standard** and **Zoom**. In **Standard**, you can select variations of the format, if you press **Variation** on Beo6. On Beo4, press **◀** or **▶**.

To optimise the sound experience for your listening position, you can select a customised listening preset and even rotate the sound to match the direction you are facing.

### Select listening preset

When you watch television or listen to music, you can select your own listening preset to optimise the sound for your listening position. You can also rotate the preset's sound so that the sound is experienced as coming from directly in front of you. Adaptive Sound Technology must be enabled and set up. See the Guide for further information.



## Useful hints

### Remote control

To enjoy the advantages of this setup, several speakers and a Beo6 remote control are necessary. If you have only a few speakers or a Beo4 remote control, this setup is not recommended and you should choose the setup without Adaptive Sound Technology described in the Guide.

### Automatic selection of listening presets

The sound automatically switches to the TV preset when you switch on the TV. You can set an AUDIO PRESET in the SOUND ADJUSTMENT menu to make sound switch to a specific customised listening preset automatically when you select an audio source.





- 20 Set up your television
- 21 Cleaning
- 22 Connection panels
- 24 First-time setup of your television

## Set up your television

Follow the guidelines for placement and connection described on this and the following pages.

### Run cables

When you connect external equipment to the system, we recommend that you connect equipment to the sockets at the far ends of the socket panel first, and work your way in towards the middle of the socket panel. This allows you access to the necessary sockets throughout the connection procedure.

- 1 Mount the left and right cable bracket on the system as shown.
- 2 Open the cable brackets, make the necessary connections, run the cables down through the brackets, and close the brackets.
- 3 When connections are complete, attach the cable cover by sliding the cable cover down over the cable brackets. The tabs (A) should fit the gaps in the cable cover.
- 4 Press the cable cover down lightly until it clicks into place. To remove the cable cover, press the tabs (A) inward with your thumbs while lifting the cable cover with your fingers.

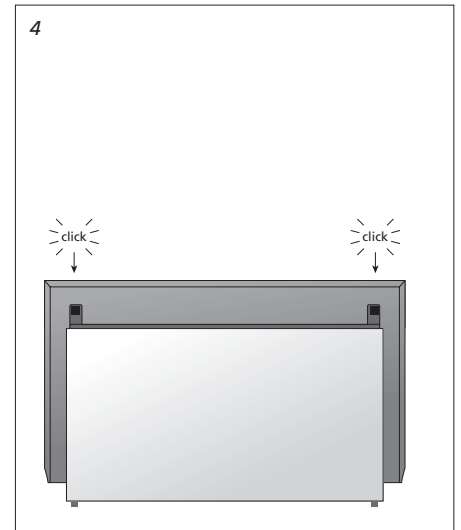
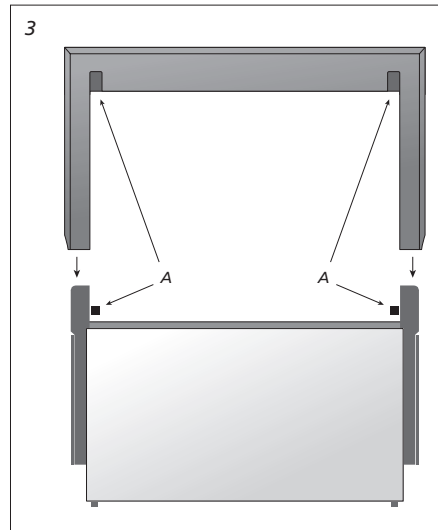
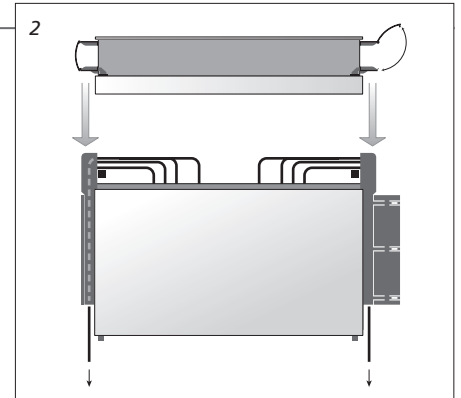
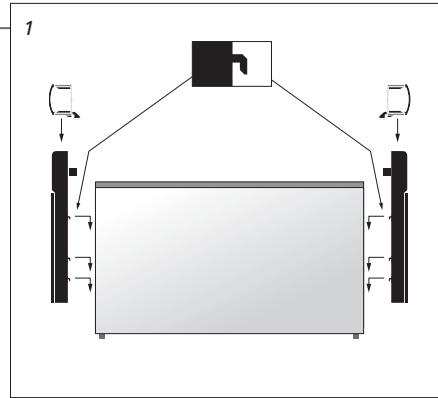

## Important

**Ventilation** To ensure proper ventilation, allow for at least 2" (5 cm) of space on each side of the TV and 4" (10 cm) above it. Do not cover the ventilation holes on the rear. At overheating (flashing standby indicator and an on-screen warning), switch the TV to standby, not off, in order for the TV to cool down. You cannot operate the TV during this time.

**NOTE!** Do not allow still pictures, such as logos, video games, computer images, and images displayed in 4:3 format, to be displayed on the screen for an extended period of time. This can cause a permanent after-image to remain on the screen.

### IR-receiver for a projector

If you have both a television screen and a projector, and the projector screen covers the IR-receiver when in use, you must mount a second IR-receiver.

The IR-receiver receives signals from your remote control and sends them to the system, which then sends control signals to the connected equipment. Make sure the IR-receiver is placed in such a way that it can receive remote control signals. If the IR-receiver is placed incorrectly, the light emitted by the connected equipment can impede remote control operation of your television.

When you have mounted the IR-receiver as shown on this page, connect it to the IR-IN (mini-jack) socket on your system.

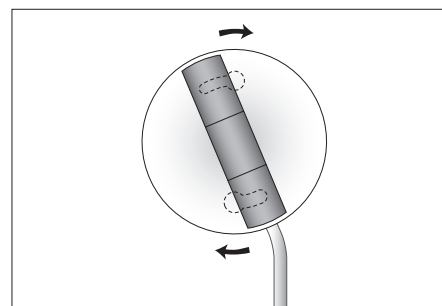
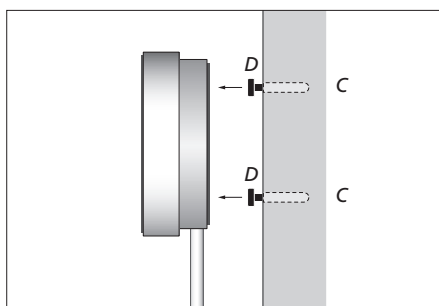
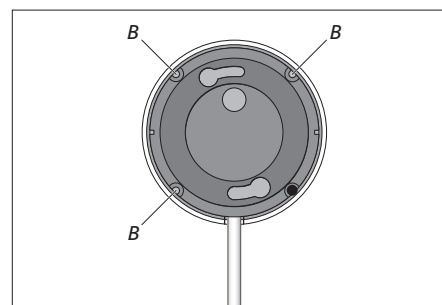
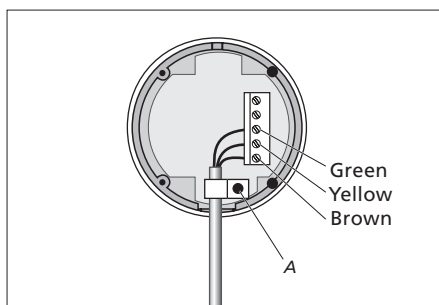
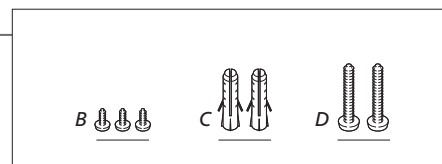
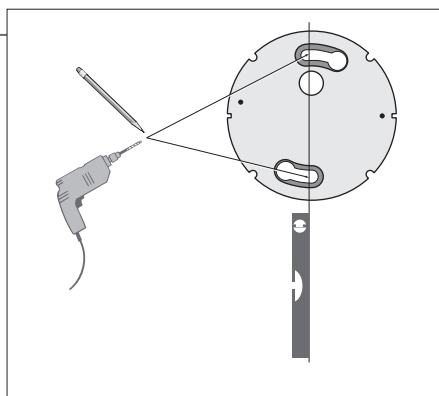

## Cleaning

- Maintenance** Regular maintenance, such as cleaning, is the responsibility of the user.
- Cabinet and controls** Wipe dust off the surfaces using a dry, soft cloth. To remove stains or dirt, use a soft, damp cloth and a solution of water and mild detergent, such as washing-up liquid.
- Never alcohol** Never use alcohol or other solvents to clean any parts of the TV.

## Connection panels

Any equipment you connect to the main connection panel must be registered in the CONNECTIONS menu. Equipment connected to the side connection panel can be registered in the CONNECTIONS menu.

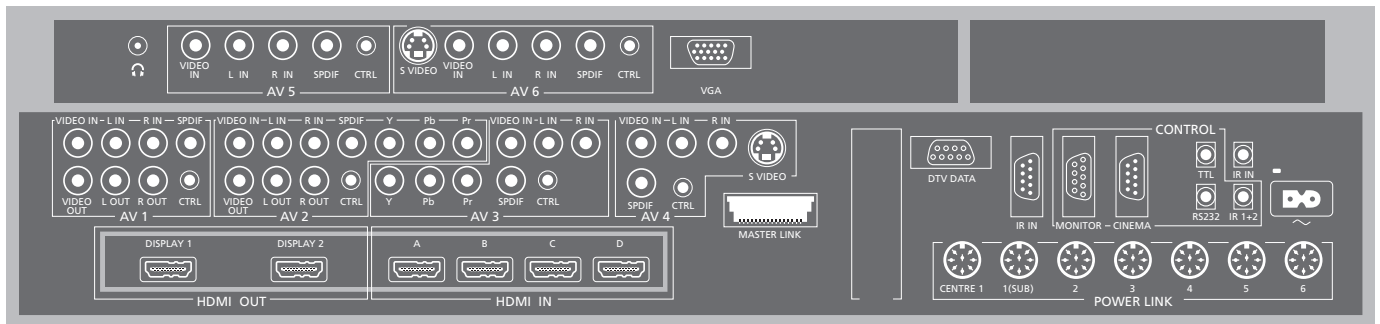

### AV1

Socket group for AV connection of a primary recorder or set-top box. You can also connect other types of extra video equipment.

### AV2

Socket group for AV connection of additional video equipment.

### AV3

Socket group for AV connection of additional video equipment. The TV keeps a signal path open between a recorder connected to the AV1 socket and a recordable source connected to the AV3 socket. This allows you to set the source on AV3 to switch on automatically, as well as set a recorder on AV1 for timed recording of the source on AV3, provided your connected equipment supports these functions.

### AV4

Socket group for AV connection of additional video equipment.

### AV5

Socket group for AV connection of additional video equipment. You can also connect a BeoMaster, a camera or a camcorder.

### AV6

Socket group for AV connection of additional video equipment. You can also connect a camera or a camcorder.

### CTRL (AV1 – AV6)

For IR control signals to external equipment connected to an AV socket.

### L-IN, R-IN (AV1 – AV6)

Right and left line input. AV5 and AV6 is for audio connection of, e.g., a camera or camcorder.

### L–R OUT (AV1 – AV2)

Right and left line output.

### VIDEO IN (AV1 – AV6)

For video signal. On AV5 and AV6 you can connect a camera or a camcorder.

### VIDEO OUT (AV1 – AV2)

For a video recorder.

### Y – Pb – Pr (AV2 – AV3)

For video signals from an external source, e.g. HDTV source. You can use the socket in conjunction with an AV socket or a digital audio socket.

### SPDIF (AV1 – AV6)

Digital audio input socket, e.g. DVD player.

### S VIDEO (AV4, AV6)

For the connection of equipment with Y/C output, e.g., a game console.

## Useful hints

**Mains cord** Connect the ~ socket on the main connection panel of your TV to the wall outlet. The TV is in standby mode and ready to be used.

**NOTE!** Video recorders can only be connected to the AV1 and AV2 socket groups, as these are the only sockets groups for video output. Connect the primary recorder to AV1 and the secondary recorder to AV2.

Some sockets on the illustration of the main connection panel may be occupied by internal connections. Do not disconnect the cables from these sockets!

#### HDMI OUT (DISPLAY 1 - 2)

Connect a plasma screen and/or a projector. If you only connect a screen or a projector, connect it to DISPLAY 1, otherwise connect the screen to DISPLAY 1 and the projector to DISPLAY 2. You cannot connect two screens or two projectors at the same time.

#### HDMI IN (A–D)

For High Definition Multimedia Interface video source or PC. An HDMI socket may be occupied by built-in video equipment. The sources can be registered to any of the AV socket groups. To expand the number of HDMI sockets, connect an HDMI Expander to the HDMI C socket.

#### DTV DATA

For future use.

#### MASTER LINK

For a compatible Bang & Olufsen audio or video system. The socket is also used for BeoLink distribution of sound and picture throughout the house.

#### CENTRE 1

For connection of a centre speaker, e.g. BeoLab 7. For further information, see the speaker's own guide.

#### POWER LINK 1–6

For connection of external speakers in a surround sound setup. See the Guide for further information.

#### 1 (SUB)

For connection of up to two Bang & Olufsen subwoofers. A cable splitter for such connections is available from your Bang & Olufsen retailer.

#### IR IN (9-pin)

For the screen's IR-receiver enabling remote control operation.

#### MONITOR

For a plasma screen.

#### CINEMA

For a Home Automation system.

#### TTL/RS232

Only for use in Hotel setups.

#### IR IN (mini-jack)

For an extra IR-receiver when the TV is set up with a projector.

#### IR 1+2

For an external IR-transmitter used with Home cinema setups or an HDMI Expander.

#### ~ – Mains supply

Connection to the mains supply.

#### VGA

Socket for connection of a High Definition video source or a PC. You can also use this socket for connection of a BeoMaster.

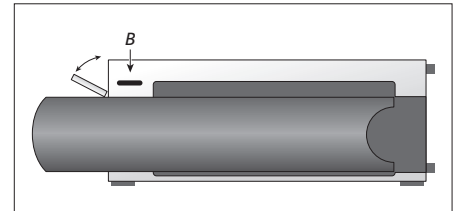

For access to the sockets for temporary connections, press the button (B) on the right side of the system and the door opens automatically. You can close the door manually.

#### PHONES

For connection of stereo headphones.

- > To mute speakers turn the volume wheel quickly counter-clockwise. (Beo4: Press in the middle of the  $\wedge \vee$  button).
- > Turn the volume wheel either way to adjust volume in headphones. (Beo4: Press  $\wedge$  or  $\vee$ ).
- > To restore sound in speakers, turn the volume wheel quickly counter-clockwise. (Beo4: Press the middle of the  $\wedge \vee$  button).

*NOTE! Prolonged listening at high volume levels can cause hearing damage!*

## First-time setup of your television

This first-time setup procedure is activated when the TV is connected to the mains and switched on for the first time. If you want to change your setup at a later date, you can access the same menus and update your settings.

### Switch on the TV

It takes the TV approx. 20 seconds to start up and become ready for use.

TV

Switch on

### Select settings

You are led through the following settings only when you switch on the TV for the first time.\*<sup>1</sup> However, the sequence of menus depend on the connections and settings you make.

◀◀▶▶

or

<◇>

●

Select setting

Accept and go to next menu item

REMOTE CONTROL

Disable or enable the navigation button on your remote control\*<sup>2</sup>

TUNER SETUP

Disable internal TV tuner

CONNECTIONS

Register connected equipment

## Information

**Connections** Select the type of equipment connected to each socket, the sockets used, the product name, and the source name.

<sup>1</sup>\*NOTE! When you have selected the preferred settings in a menu, you may have to press the **green** button to continue to the next menu in the first-time setup procedure. Follow on-screen instructions.

## Calibrate the speakers

Set up the speakers to optimise sound from your listening position. To enjoy Adaptive Sound Technology several speakers and a Beo6 remote control are necessary.

### AST ON/OFF

Disable or enable Adaptive Sound Technology

#### AST ON:

SPEAKER SETUP

TV LISTENING PRESET

CINEMA LISTENING PRESET

#### AST OFF:

SPEAKER TYPES

SPEAKER ROLES

SPEAKER DISTANCE

SPEAKER LEVEL

First-time setup of loudspeakers applies only to speakers for TV viewing. See the Guide for further information.

### SOUND ADJUSTMENT

### SOUND ADJUSTMENT

Adjust volume, bass, treble and loudness and preset two default speaker combinations.

### SOUND SETUP

Make settings for each LISTENING PRESET. See the Guide for further information.

## Make standby settings

Set the TV to switch itself to standby after some time with no operation. See the Guide for further information.

### AUTO STANDBY

Make standby settings for the TV

<sup>2</sup>\***Navigation button** If you have a Beo4 without navigation button or if your Beo4 is not set to the correct mode, you cannot enable the navigation button. See the Beo4 guide or contact your Bang & Olufsen retailer for further information.

**Projector** If you have connected a projector and not a screen, you must switch off the television after first-time setup and then switch it on again for your settings to take effect.

**NOTE!** For further information about remote controls and first-time setup, see the Guide.

### Waste Electrical and Electronic Equipment (WEEE) – Environmental protection



Electrical and electronic equipment, parts and batteries marked with this symbol must not be disposed of with normal household wastage; all electrical and electronic equipment, parts and batteries must be collected and disposed of separately.

When disposing of electrical and electronic equipment and batteries by use of the collection systems available in your country, you protect the environment, human health and contribute to the prudent and rational use of natural resources.

Collecting electrical and electronic equipment, batteries and waste prevents the potential contamination of nature with the hazardous substances which may be present in electrical and electronic products and equipment.

Your Bang & Olufsen retailer will advise you of the correct way of disposal in your country.

#### *For the US-market only!*

NOTE: This equipment has been tested and found to comply with the limits for a class B digital device, pursuant to part 15 of the FCC Rules. These limits are designed to provide reasonable protection against harmful interference in a residential installation.

This equipment generates, uses and can radiate radio frequency energy and, if not installed and used in accordance with the instructions, may cause harmful interference to radio communications. However, there is no guarantee that interference will not occur in a particular installation. If this equipment does cause harmful interference to radio or television reception, which can be determined by turning the equipment off and on, the user is encouraged to try to correct the interference by one or more of the following measures:

- Reorient or relocate the receiving antenna.
- Increase the separation between the equipment and receiver.
- Connect the equipment into an outlet on a circuit different from that to which the receiver is connected.
- Consult the retailer or an experienced radio/TV technician for help.

#### *For the Canadian market only!*

This class B digital apparatus meets all requirements of the Canadian Interference-Causing Equipment Regulations.

This product complies with applicable environmental legislation throughout the world.

If the product is equipped with a grounded mains lead and 3-pin plug, the product shall be connected to a mains socket wall outlet with a protective earth connection. The ground pin of the mains plug must not be removed, due to the danger of electric shock. If a wall outlet with protective earth is not available, an electrician should be contacted.

This product incorporates copyright protection technology that is protected by U.S. patents and other intellectual property rights. Use of this copyright protection technology must be authorized by Rovi, and is intended for home and other limited viewing uses only unless otherwise authorized by Rovi. Reverse engineering or disassembly is prohibited.

HDMI, the HDMI Logo and High-Definition Multimedia Interface are trademarks or registered trademarks of HDMI Licensing LLC.



Manufactured under license from Dolby Laboratories. Dolby, Pro Logic, and the double-D symbol are registered trademarks of Dolby Laboratories. Confidential unpublished works. Copyright 1992–2003 Dolby Laboratories. All rights reserved.



Manufactured under license under U.S. Patent #'s: 5,451,942; 5,956,674; 5,974,380; 5,978,762; 6,487,535; 7,003,467; 7,212,872 & other U.S. and worldwide patents issued & pending. DTS, DTS Digital Surround, ES, and Neo:6 are registered trademarks and the DTS logos, and Symbol are trademarks of DTS, Inc. © 1996–2008 DTS, Inc. All Rights Reserved. U.S. Patent's 6,836,549; 6,381,747; 7,050,698; 6,516,132; and 5,583,936



351114112060007









